

# 1447S Single Door Disconnect Enclosures - NEMA 12, 13

ABB Controls, Allen Bradley, Cutler Hammer, General Electric, Siemens I-T-E Max-Flex™, Square D

Disconnect



Cutout Detail



Wallmount Enclosures

## Application

Designed to house the following safety disconnect equipment:

- **ABB Controls** flange-mounted variable depth operating mechanism for disconnect switches and circuit breakers. Also cable version for circuit breakers.
- **Allen Bradley** 1494V variable depth flange mounted disconnect switches and circuit breaker operators. Will not accept Allen Bradley 1494F disconnect switches, 1494D circuit breaker operators.
- **C-H Westinghouse** C361 flange mounted variable depth operating mechanism with disconnect switches and C371 flange mounted variable depth operating mechanisms for circuit breakers. Also Flex-Shaft™ handle mechanisms for circuit breakers.
- **General Electric** Type STDA flange handles and variable depth operating mechanism for disconnect switches and circuit breakers. Also SpectraFlex™ cable operators for circuit breakers.
- **Siemens I-T-E Max-Flex™** flange mounted variable depth handles for disconnect switches and circuit breakers.
- **Square D** class 9422 disconnect switches with flange mounted variable depth operating mechanisms or cable mechanisms and Class 9422 flange-mounted variable depth operating mechanisms or cable mechanisms for circuit breakers. Will not accept Square D Class 9422 bracket-mounted disconnect devices, 9422TG1 or TG2 devices.

## Standards

- UL 508 Type 12, 13
- CSA Type 12, 13
- **Complies with**
  - NEMA Type 12 and 13
  - JIC EGP-1-1967
  - IEC 60529, IP54
- Appropriate components are required to maintain these standards.

## Construction

- Formed 14-gauge steel.
- Continuously welded seams.
- Larger sizes include door and body stiffeners.
- Welded brackets provide for enclosure mounting.
- Formed lip on door and enclosure exclude flowing liquids and contaminants.
- Cutouts and holes are provided to suit the handle, operating mechanism and door closing mechanism.
- Continuously hinged doors may be removed by pulling the hinge pin.
- Latch pivots and cover interlock brackets are welded to the door.
- Cover latch bars for door handles are provided.
- Collar studs are provided for mounting inner panels.
- A removable 12 gauge inner panel is included.
- Oil resistant gaskets are permanently secured and mechanically retained.
- A bonding stud is provided on the door and a grounding stud is provided in the enclosure.
- A literature pocket is provided.

## Note:

- Disconnects, operating mechanisms and door hardware are not provided with the enclosure, and must be ordered separately from the manufacturer.
- Enclosures with an "A" dimension under 40" require 2 point door closing hardware.
- Enclosures with an "A" dimension 40" or more require 3 point door closing hardware.

## Finish

- Door and enclosure are phosphatized and finished in ANSI 61 gray recoatable powder coating on the outside.
- Enclosure interior is finished in white powder coating.
- Inner panel is finished in white powder coating.

## Accessories

- Additional inner panels  
...see page **436**
- Air conditioners...see page **349-367**
- Blowers...see page **392**
- Breather kits...see page **400-401**
- Doorstop kits...see page **453**
- Drip shield kits...see page **451**
- Enclosure stabilizers...see page **456**
- Filter fans...see page **371-384**
- Floor stand kits...see page **393-396**
- Heaters...see page **397**
- Thermostats...see page **397**
- Window kits...see page **449**

# 1447S Single Door Disconnect Enclosures - NEMA 12, 13

ABB Controls, Allen Bradley, Cutler Hammer, General Electric, Siemens I-T-E Max-Flex™, Square D

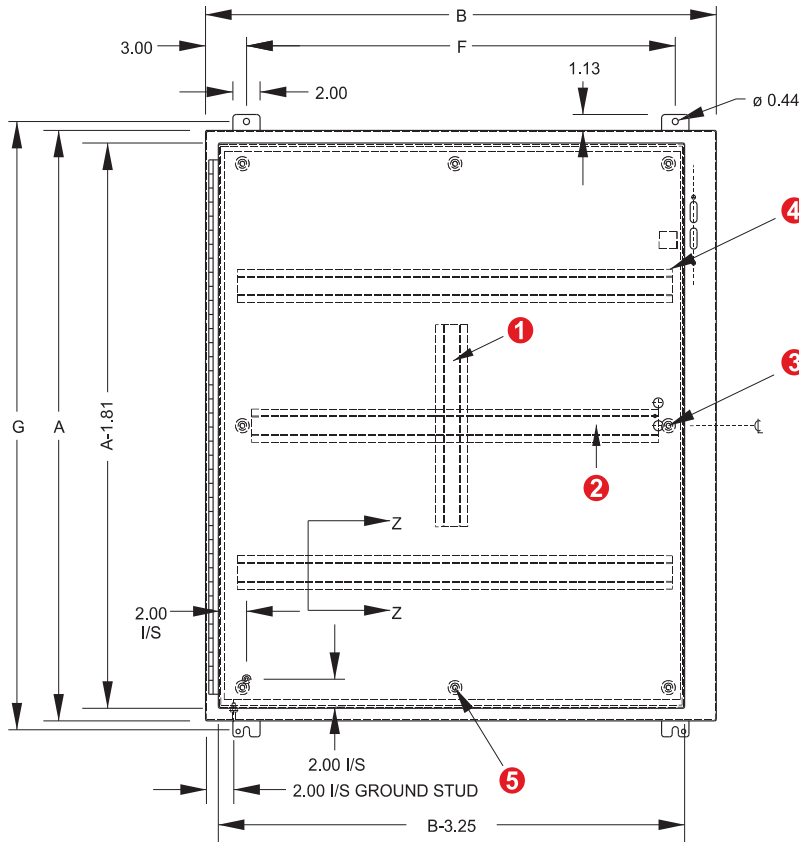

**Front View**

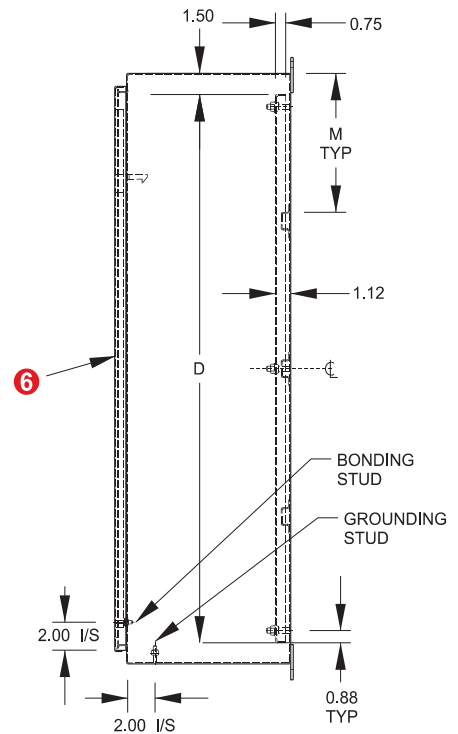

**Side View**

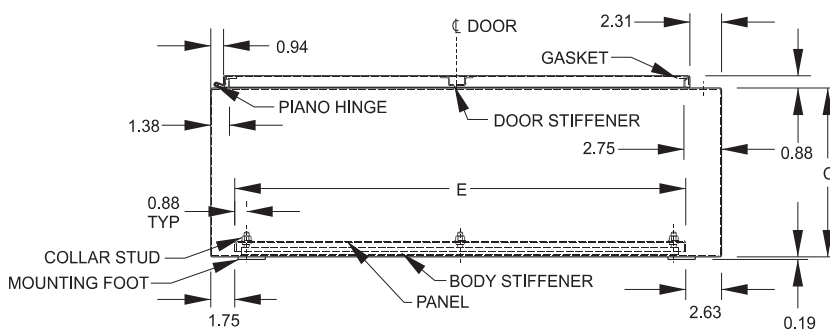

**Top View**

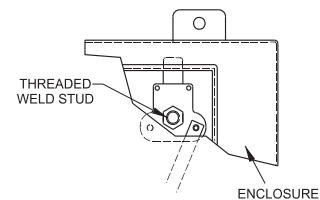

**Closing Mechanism**  
Catches top of enclosure only

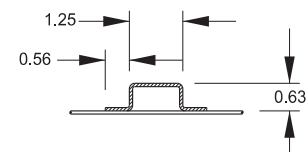

**Section Z-Z**

When A=	M=
36	9.00
42	9.88
48	11.38
60	14.38

- 1 Vertical body stiffener req'd on 1447SG only.
- 2 Omit center body stiffener if A is less than 41".
- 3 Omit 2 middle studs if A is less than 31".
- 4 Omit body stiffeners if B is 28" or less.
- 5 Omit 2 middle studs if B is less than 32".
- 6 Omit door stiffener if B is 32" or less except if AxB is 42"x31.38".

# 1447S Single Door Disconnect Enclosures - NEMA 12, 13

ABB Controls, Allen Bradley, Cutler Hammer, General Electric, Siemens I-T-E Max-Flex™, Square D

**Disconnect**
**Wallmount Enclosures**

Part No.	Panel Size					Mounting Center		Ship Wt. lbs	Center Stiffener <sup>2</sup>
	A	B	C	D	E	F	G		
1447SA8	20	21.38	8	17	17	15.38	21.25	51	N
1447SB8	24	21.38	8	21	17	15.38	25.25	60	N
1447SC8	24	25.38	8	21	21	19.38	25.25	71	N
1447SD8	30	21.38	8	27	17	15.38	31.25	74	N
1447SE8	30	25.38	8	27	21	19.38	31.25	87	N
1447SF8	36	25.38	8	33	21	19.38	37.25	98	N
1447SG8	36	31.38	8	33	27	25.38	37.25	121	N
1447SH8	42	31.38	8	39	27	25.38	43.25	135	I
1447SJ8	42	37.38	8	39	33	31.38	43.25	154	I
1447SK8	48	37.38	8	45	33	31.38	49.25	172	I
1447SL8	60	37.38	8	57	33	31.38	61.25	248	I
1447SA10	20	21.38	10	17	17	15.38	21.25	52	N
1447SB10	24	21.38	10	21	17	15.38	25.25	63	N
1447SC10	24	25.38	10	21	21	19.38	25.25	71	N
1447SD10	30	21.38	10	27	17	15.38	31.25	80	N
1447SE10	30	25.38	10	27	21	19.38	31.25	90	N
1447SF10	36	25.38	10	33	21	19.38	37.25	100	N
1447SG10	36	31.38	10	33	27	25.38	37.25	126	N
1447SH10	42	31.38	10	39	27	25.38	43.25	143	I
1447SJ10	42	37.38	10	39	33	31.38	43.25	193	I
1447SK10	48	37.38	10	45	33	31.38	49.25	180	I
1447SL10	60	37.38	10	57	33	31.38	61.25	255	I
1447SE12	30	25.38	12	27	21	19.38	31.25	100	N
1447SG12	36	31.38	12	33	27	25.38	37.25	130	N
1447SH12	42	31.38	12	39	27	25.38	43.25	150	I
1447SJ12	42	37.38	12	39	33	31.38	43.25	200	I
1447SK12	48	37.38	12	45	33	31.38	49.25	220	I
1447SL12	60	37.38	12	57	33	31.38	61.25	265	I
1447S46L12	60	37.38	12	57	34.5	31.38	61.25	265	I
1447SG16	36	31.38	16	33	27	25.38	37.25	150	N
1447SK16	48	37.38	16	45	33	31.38	49.25	200	I
1447SL16	60	37.38	16	57	33	31.38	61.25	265	I

<sup>2</sup> Center stiffener; N = Not Included I = Included

## Space Occupied by Disconnect

Note: "K" = 4.75 when "C" = 8.00  
 "K" = 7.09 when "C" = 10.00  
 "K" = 11.62 when "C" = 12.00  
 "K" = 11.62 when "C" = 16.00  
 "K" = 18.38 for 1447S46L12  
 "P" = Wiring Space

Disconnects will occupy space on panel shown by dimensions "K", "L" and "M".

Wiring space "P" is available when disconnect is installed in the enclosure.

\*The disconnect information and space occupied tables based on data supplied by disconnect manufacturer's bulletins. Hammond Manufacturing not responsible for dimensional accuracy.

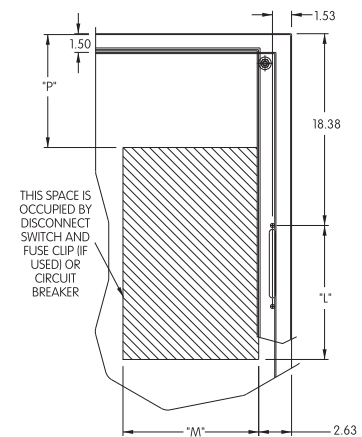
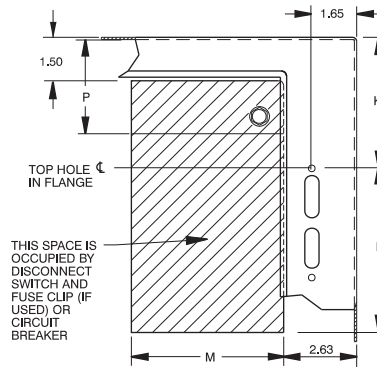

**1447S46L12 only**  
**1494V-H2 and ITE PHOHN**  
**Operating Handle**